

# EXTENDABLE CONVEYOR

---

## Single Stage Extendable Conveyor



This conveyor is designed to extend into a trailer or other freight container types to accelerate the transfer of product into, or out of, a handling system or for conveyor access openings. Available in standard sizes or to your specifications.

### FEATURES:

- Hand Crank Boom Extension And Retraction
- Hand Crank Will Position Boom Stop At Any Extension Length
- Retracts If Boom Is Hit Or Bumped When Extended
- Belt Direction: Load Or Unload
- Manual Height Adjustment On Front Stand
- VFD Duty Motorized Pulley
- One Continuous Belt
- Painted Per Customer Color

### OPTIONS:

- Lengths and Widths Available To Your Specifications
- Electrical Powered Boom Extension
- "Air" Powered Boom Extension
- Standard Power Voltages Available
- VFD Speed Controls
- Manual Height Adjustment On Rear Stand



***"FIRST CLASS DOESN'T HAVE TO COST MORE"***



WASP, Inc.  
Box 249 ■ Glenwood, MN 56334  
(320) 634-5126 FAX (320) 634-5891  
[www.waspinc.com](http://www.waspinc.com)

# EXTENDABLE CONVEYOR

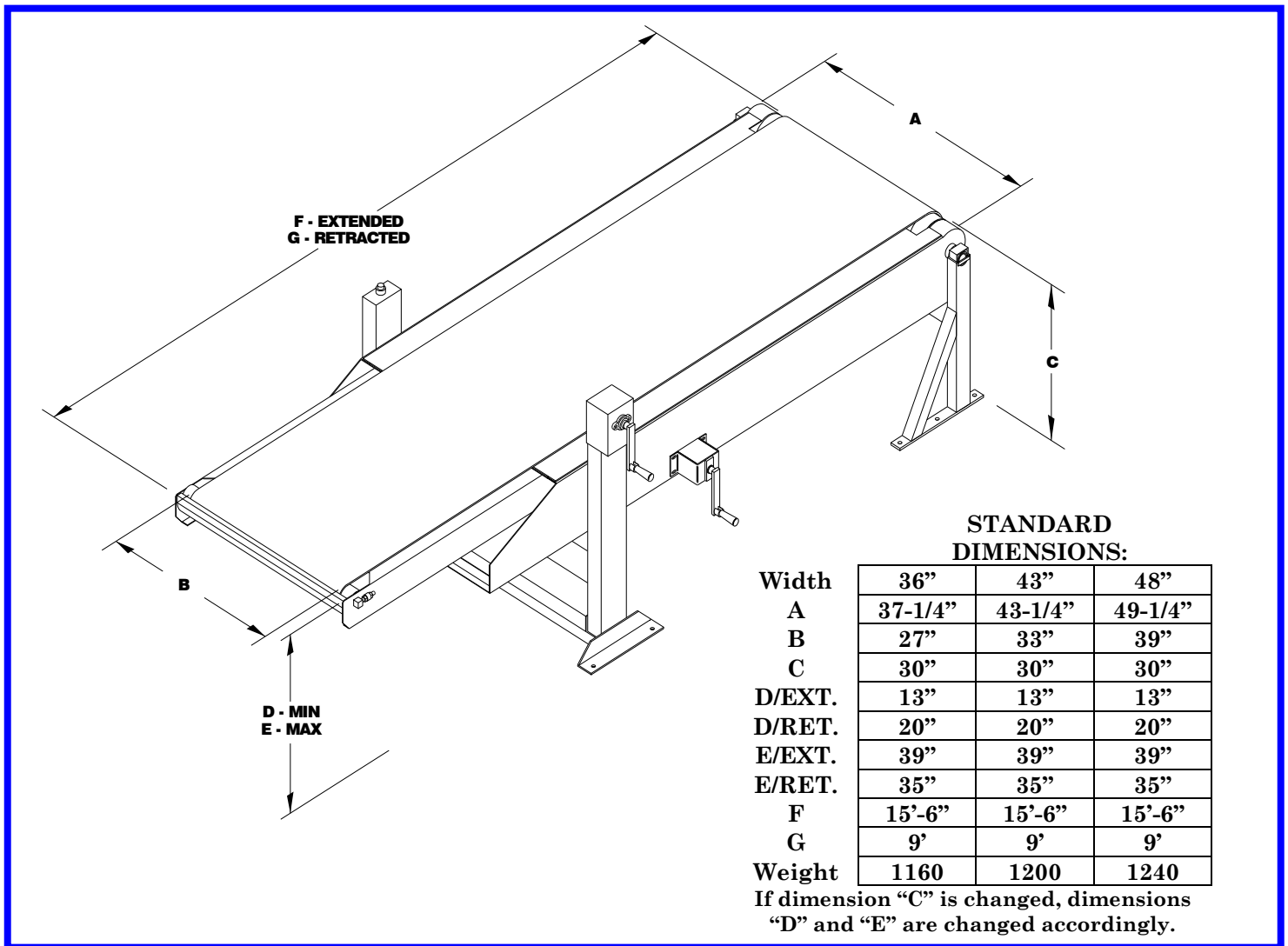

## SPECIFICATIONS:

**WEIGHT:** 1240 Lbs. Approximately

**UNIT LENGTH:** 108" Retracted **UNIT WIDTH:** 49-1/4" Overall

**BELT:** 39" Wide 120 PVC COS x FS

**DRIVE DRUM:** 7" Diameter Motorized Pulley

**END ROLLERS:** 3-1/2" Diameter with 1-7/16" Pulley Shafts

**IDLER ROLLERS:** 2-3/4" Diameter with 1-3/16" Shafts

**FRONT STAND:** 1-1/4" ACME Lifting Screws

**SIDE PANS:** 89" Long **UNIT LENGTH:** 108" Retracted

**COMMON BELT SPEEDS:** 60 fpm, 80 fpm

**BOOM EXTENSION:** 80"

**REAR STAND:** 24" Discharge Minimum or as Required

**SIDE PANS:** 89" Long



WASP, Inc.

Box 249 ■ Glenwood, MN 56334

(320) 634-5126 FAX (320) 634-5891

[www.waspinc.com](http://www.waspinc.com)