

# RJ CHARTER STAIR

---

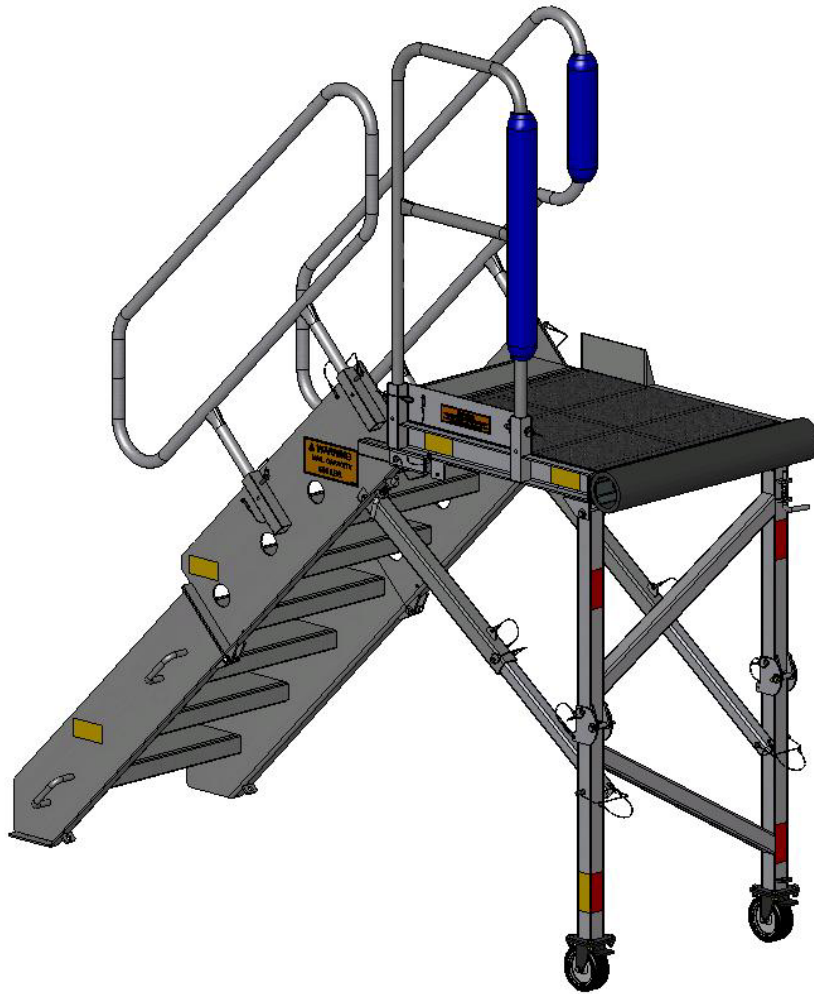

---

## MODEL A05356D

### FEATURES:

- Assembles/Dis-assembles Within Minutes
- Compact Design Allows Stair to be Transported in Aircraft Cargo Hold to be Used in Locations Without Readily Accessible GSE Equipment
- Vinyl Transport Bags Allow Unit to be Shipped Easily
- Lightweight Aluminum Design
- Non-Skid Walk Surfaces
- Rubber Bumper on Lead Edge of Deck and Padded Lead Edges of Handrails Prevent Aircraft Damage
- Rigid Mount Casters with Wheel Locks

***“FIRST CLASS DOESN’T HAVE TO COST MORE”***

---

Watkins Aircraft Support Products  
Box 249 ■ Glenwood, MN 56334  
(320) 634-5885 FAX (320) 634-5881

# RJ CHARTER STAIR

---

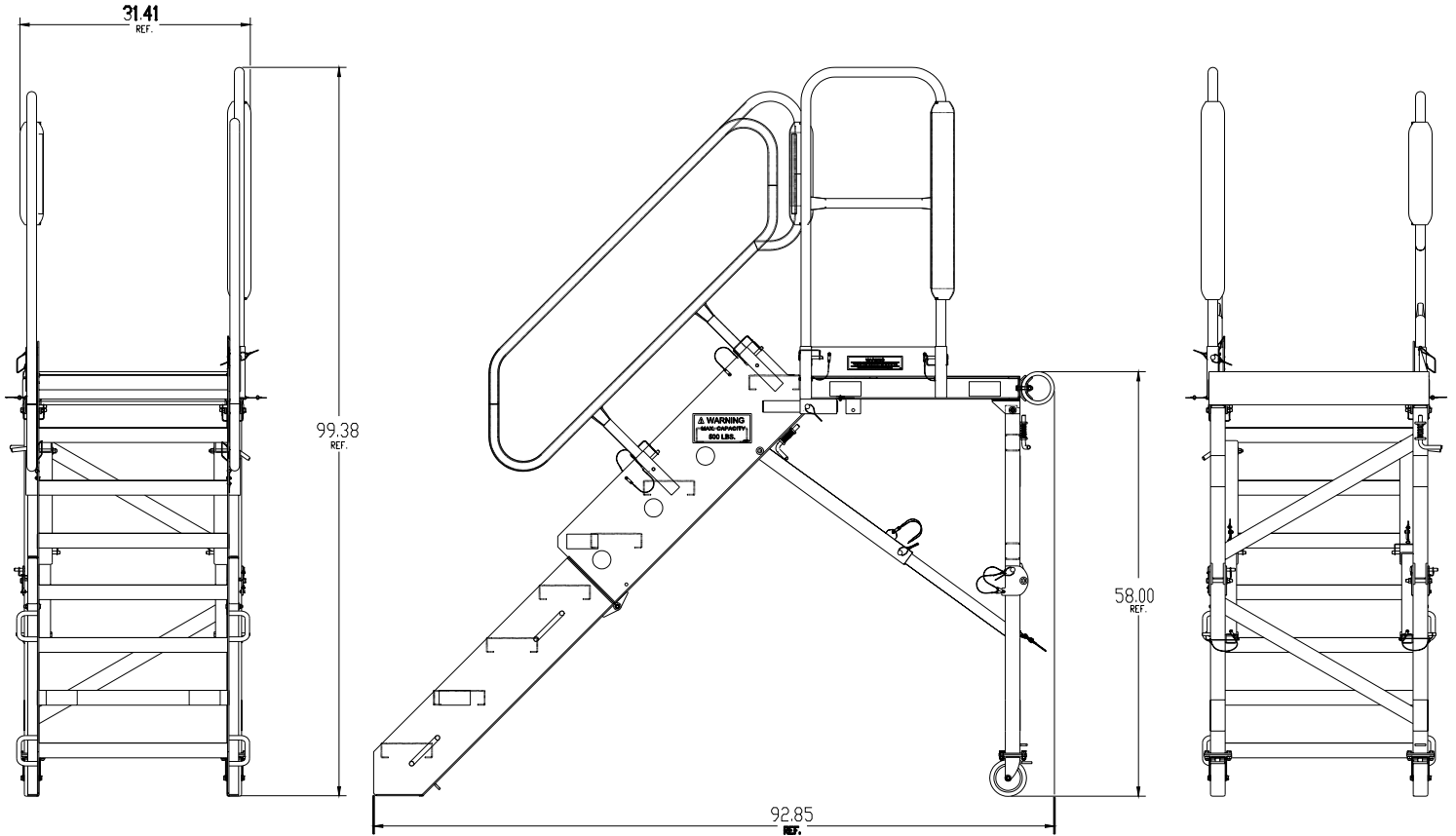

---

## A05356D Passenger Stair

### SPECIFICATIONS:

**TOTAL WEIGHT: 170 LBS.**

**STAIR RISER: 82 LBS.**

**DECK/LEG ASSEMBLY: 70 LBS.**

**HANDRAILS: 18 LBS.**

**CASTERS: Two 5.50" Diameter Rigid  
Casters With Locks.**

**CONSTRUCTION: Structural Aluminum  
Main Frame with Morton® Tread Grip  
Steps.**

**OVERALL LENGTH: 92.88 inches.**

**OVERALL WIDTH: 34.50 inches.**

**PLATFORM HEIGHT: 58.00 inches.**

**OVERALL HEIGHT: 99.38 inches**

**RUNNING GEAR: Caster Wheels.**

**CAPACITY: 500 LBS.**