

TOWABLE PASSENGER STAIR



MODEL A04973D

FEATURES:

- Movable Handrails to Clear Aircraft Door
- Services Various Passenger Door Sill Heights, 86” to 134”
- Adjustable Platform Height Using Hand Pump
- Modesty Panels on all Step and Platform Handrails
- Battery Powered Lighting System with Onboard Charger
- Extended Handrails for Ease of Positioning by Ground Personnel
- Morton® Non-Slip Walk Surface
- Equipped With Towbar
- Hydraulic Stabilizers
- Epoxy Powdercoated per Customer Color

OPTIONAL:

- Canopy/Side Curtain

“FIRST CLASS DOESN’T HAVE TO COST MORE”

Watkins Aircraft Support Products
Box 249 ■ Glenwood, MN 56334
(320) 634-5885 FAX (320) 634-5881

TOWABLE PASSENGER STAIR

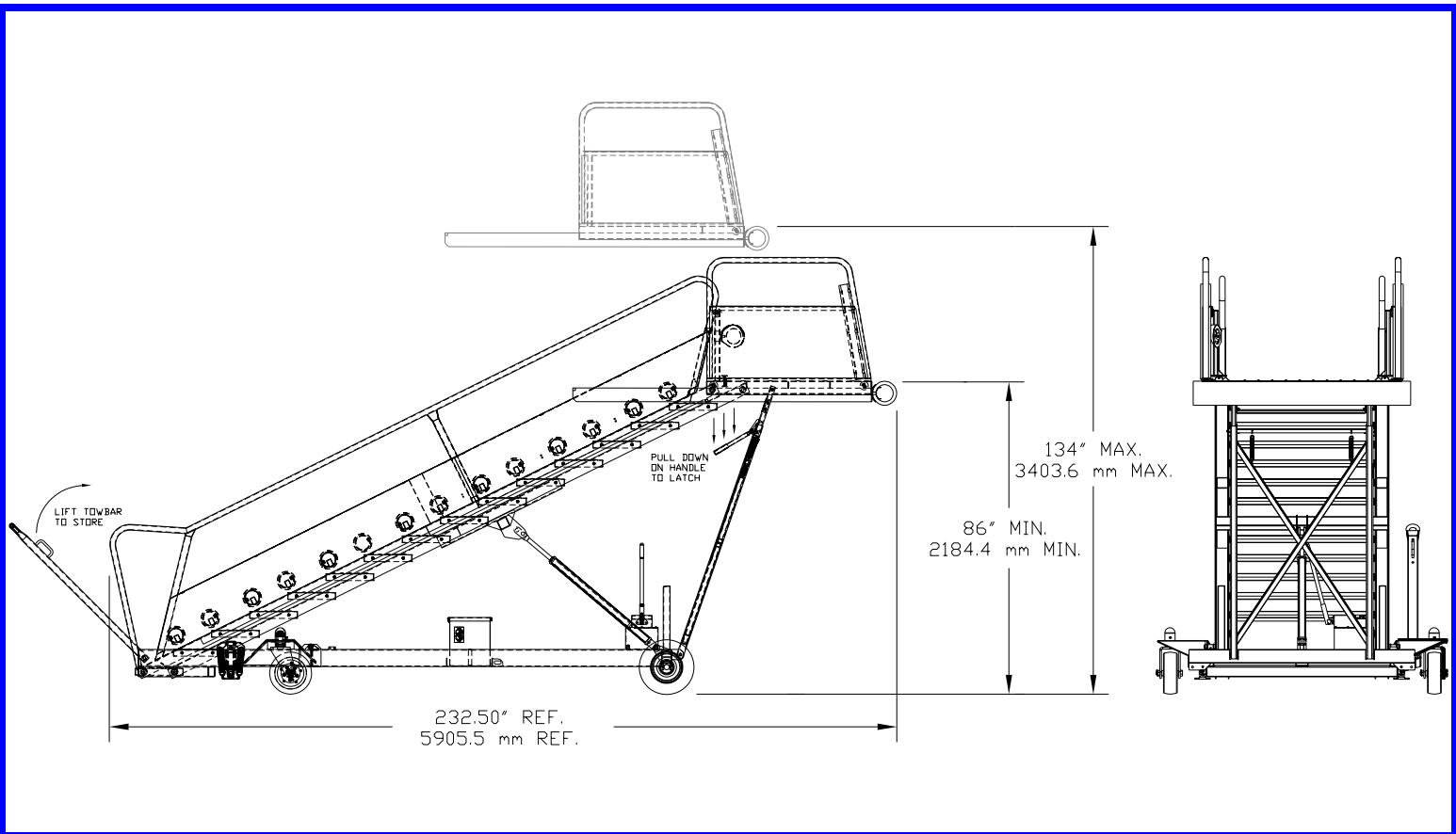

A04973D Passenger Stair

SPECIFICATIONS:

RUNNING GEAR: Front Rigid Axle with Solid Rubber Tires. Single Rear Heavy Duty Steering Caster.

LEVELING JACK: Single Lever Hydraulic Type.

BATTERY: 24 Deep Cycle Group.

CONSTRUCTION: Heavy Duty Steel Main Frame With Morton Tread Grip Walk Surface.

CAPACITY: 500 LBS (226.8 kg) on Platform; 2500 LBS (1133.98kg) on Complete Stair.

TOWBAR: Folding With 3.00" Diameter Eye.

Watkins Aircraft Support Products
Box 249 ■ Glenwood, MN 56334
(320) 634-5885 FAX (320) 634-5881