

747 TAIL SUPPORT STANCHION



**Model
A04093D**

FEATURES:

- Built in Accordance with Boeing Document D6-30108
- Towable - 5 MPH Maximum
- Dual 12 Volt and Hand Powered Hydraulic System Standard
- Ladder to Aid in Proper Positioning
- Epoxy Powdercoated to Resist Hydraulic Fluids
- Hot Dip Galvanizing Optional

“FIRST CLASS DOESN'T HAVE TO COST MORE”

WASP, Inc.
Box 249 ■ Glenwood, MN 56334
(320) 634-5885 FAX (320) 634-5881

747 TAIL SUPPORT STANCHION

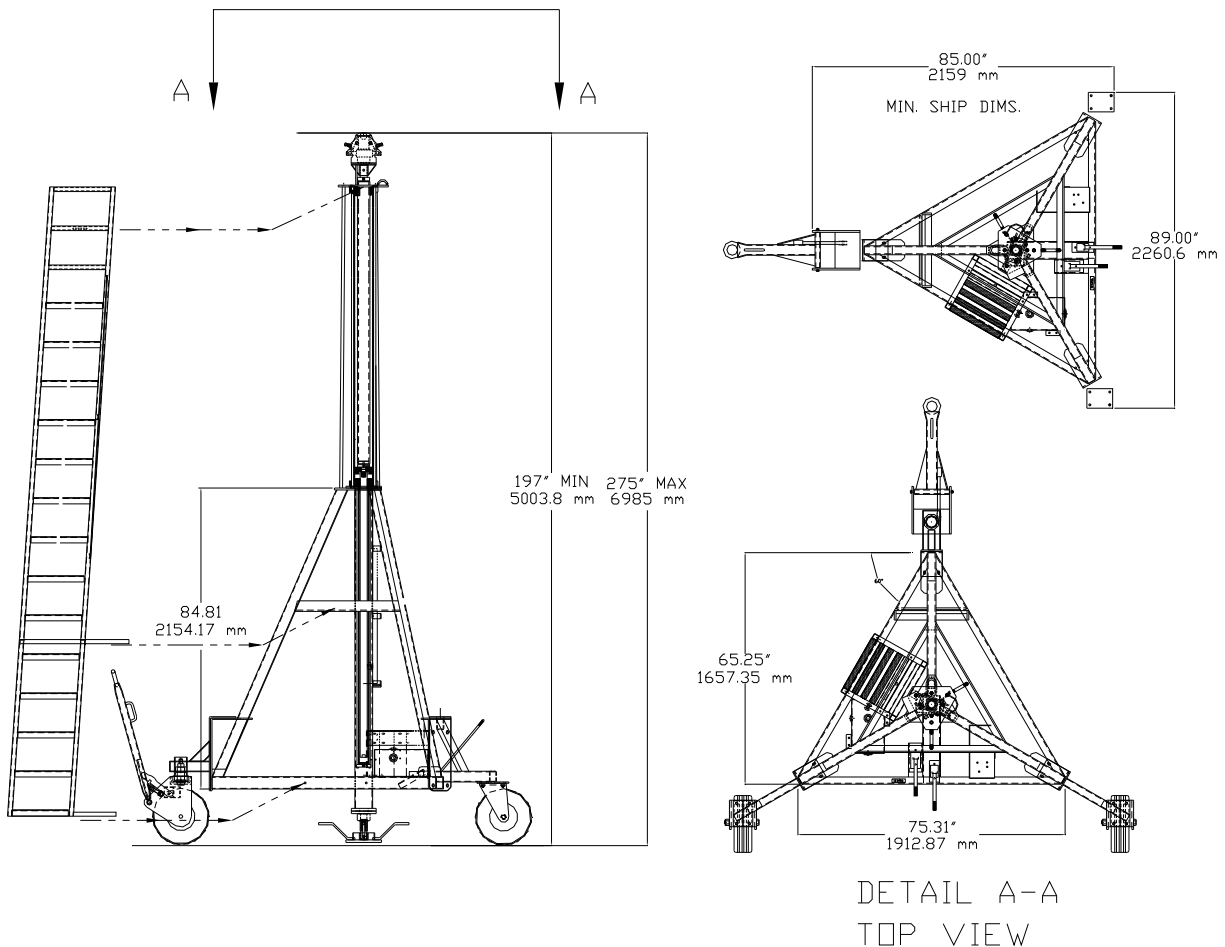

SPECIFICATIONS:

Load Capacity: 25,000 LBS. (11339.8 kg)

Overall Height Extended: 275" (6985 mm)

Overall Height Retracted: 197" (5003.8 mm)

Shipping Weight: 1700 LBS. (771.11 kg)

Shipping Dimensions: 197" (5003.8 mm) Length, 90" (2286 mm) Width, 86" (2184.4 mm) Height

Running Gear Casters: 3-12", Two with Swivel Locks

Hydraulic System:

Powered By: 12 Volt, DC Supplied by Tow Vehicle

Manual: Dual Hand Pumps, 500 psi and 1500 psi

Accumulator: Nitrogen Charged, Piston Type

WASP, Inc.
Box 249 ■ Glenwood, MN 56334
(320) 634-5885 FAX (320) 634-5881