

CREW ACCESS STAIR



**Adjustable Height
Mobile Type**

FEATURES:

- Stabilizer Strut and Two Leveling Jacks for Stability
- Vinyl Padded Bumpers on Lead Edge to Protect Aircraft
- Top Hand Rail Movable To Allow Airplane Door Opening
- Hydraulically Raised and Lowered, Then Pinned in Place
- Equipped With Towbar
- Epoxy Powdercoated per Customer Color
- Hot Dip Galvanizing Optional

“FIRST CLASS DOESN'T HAVE TO COST MORE”

WASP, Inc.
Box 249 ■ Glenwood, MN 56334
(320) 634-5885 FAX (320) 634-5881

CREW ACCESS STAIR

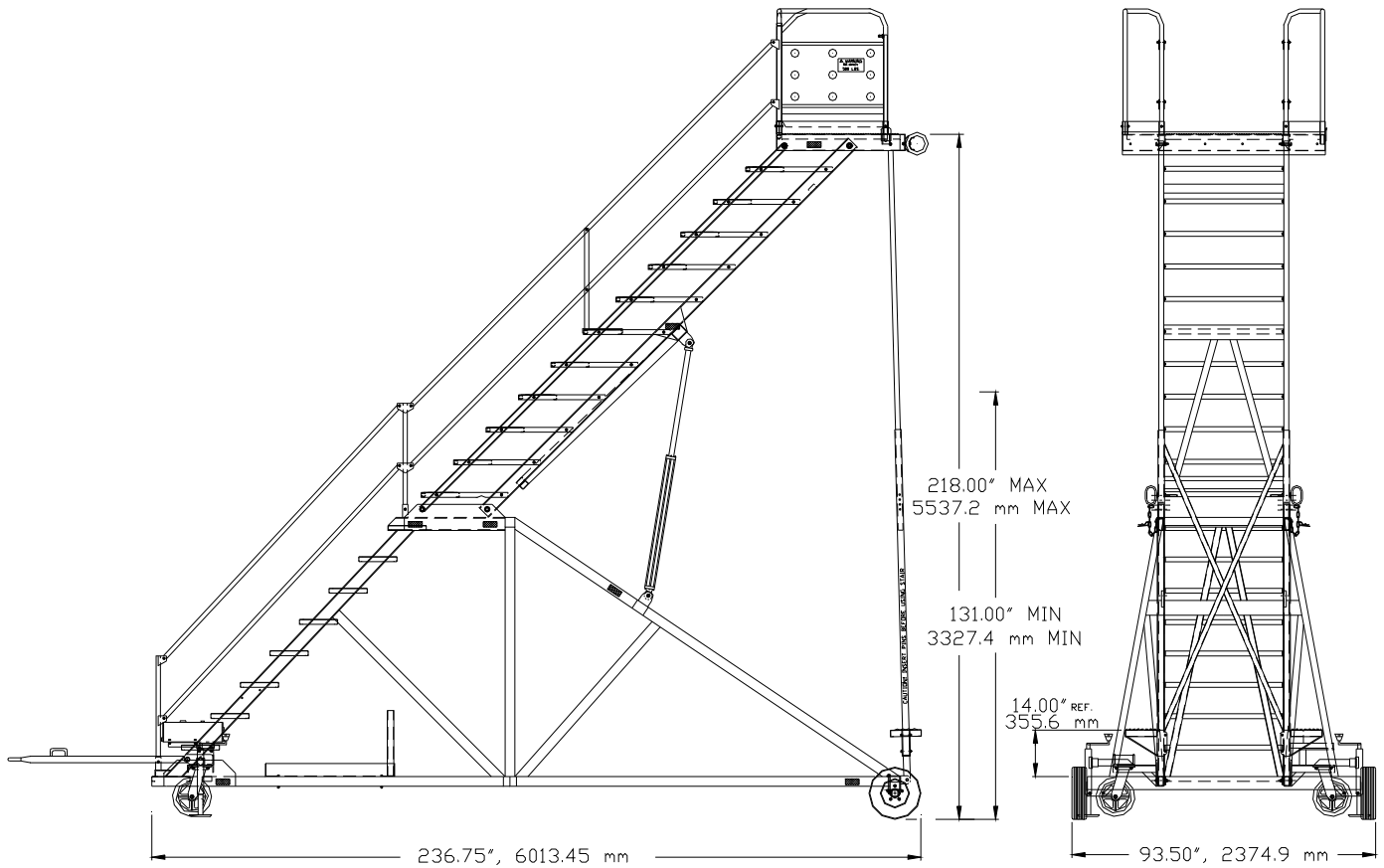

Adjustable Height Mobile Type

SPECIFICATIONS:

CASTERS: 12" Dia. Swivel With Solid Rubber Tires.

RUNNING GEAR: Fixed Rear Axle, Casters on Front.

TIRES: 16" Dia. Solid Rubber.

LEVELING JACKS: Manual Screw Type.

CONSTRUCTION: Structural Steel Main Frame With Galvanized Grip Strut Steps

CAPACITY: 500 LBS. (226.8 kg)

WASP, Inc.
Box 249 ■ Glenwood, MN 56334
(320) 634-5885 FAX (320) 634-5881