

CREW ACCESS STAIR



Model A01152D
Adjustable Height
Mobile Type

FEATURES:

- **Two Leveling Jacks for Stability**
- **Vinyl Padded Bumpers on Lead Edge to Protect Aircraft**
- **Top Hand Rail Movable To Allow Airplane Door Opening**
- **Manually or Hydraulically Raised and Lowered, Then Pinned in Place**
- **Equipped with Towbar**
- **Epoxy Powdercoated per Customer Color**
- **Hot Dip Galvanizing Optional**

“FIRST CLASS DOESN'T HAVE TO COST MORE”

Watkins Aircraft Support Products
Box 249 ■ Glenwood, MN 56334
(320) 634-5885 FAX (320) 634-5881

CREW ACCESS STAIR

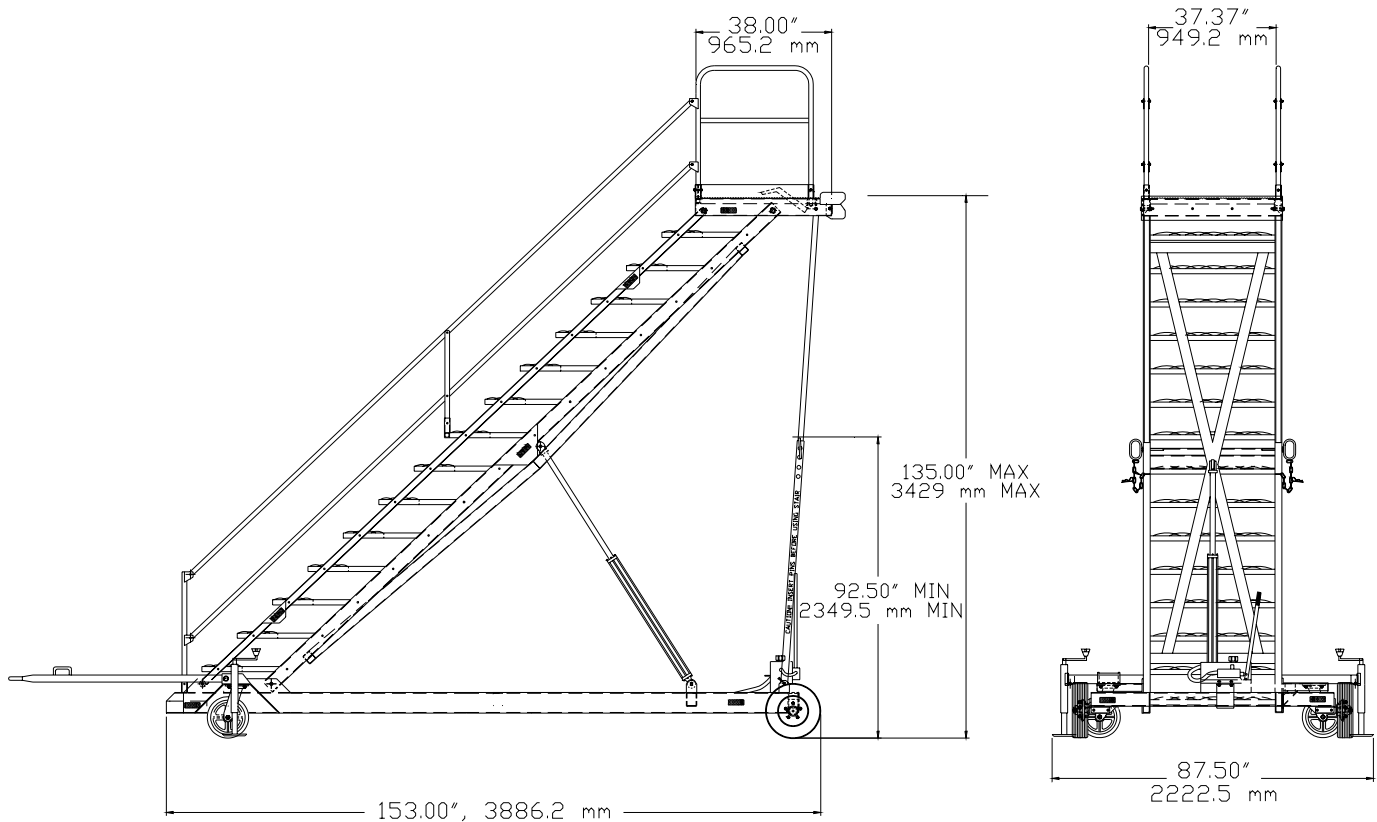

Model A01152D Adjustable Height Mobile Type

SPECIFICATIONS:

CASTERS: 12" Dia. Swivel With Solid Rubber Tires.

RUNNING GEAR: Fixed Rear Axle, Casters on Front.

TIRES: 16" Dia. Solid Rubber.

LEVELING JACKS: Manual Screw Type.

CONSTRUCTION: Structural Steel Main Frame With Grip Strut Steps.

CAPACITY: 500 LBS. (226.8 kg)

Watkins Aircraft Support Products
Box 249 ■ Glenwood, MN 56334
(320) 634-5885 FAX (320) 634-5881